

GENERAL NOTES:

The modular square footage shall be in compliance with the adopted building code. The minimum and maximum number of windows and exits shall be in accordance with code requirements for egress and Energy Compliance Reports. The adopted Plumbing Code shall govern plumbing fixture(s) required. Consideration may be taken for existing restrooms located on site. Modular may be installed on a temporary or permanent foundation system subject to the approval of the local building department.

BUILDING DESIGN DATA:

OCCUPANCY: CLASSROOM (E)
 NOMINAL: 36'-0" X 40'-0"
 AREA (NOM.): 1430 SQ. FT.
 ROOF DESIGN: DUAL or MONO
 FRAME TYPE: PERIMETER
 EXT. FINISH: PLYWOOD SIDING

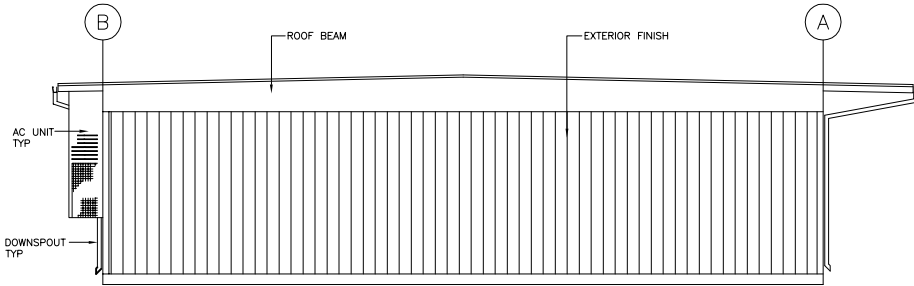

ROOF DESIGN: DUAL PITCH

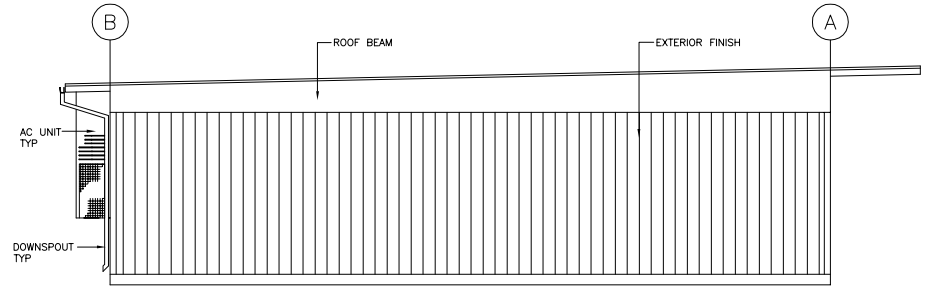

ROOF DESIGN: MONO

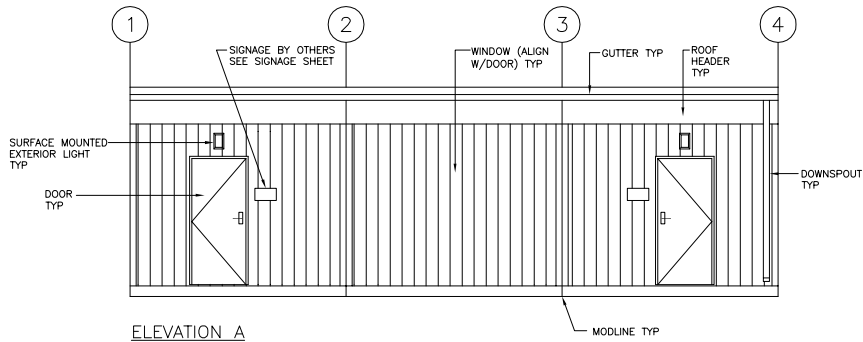

ELEVATION A

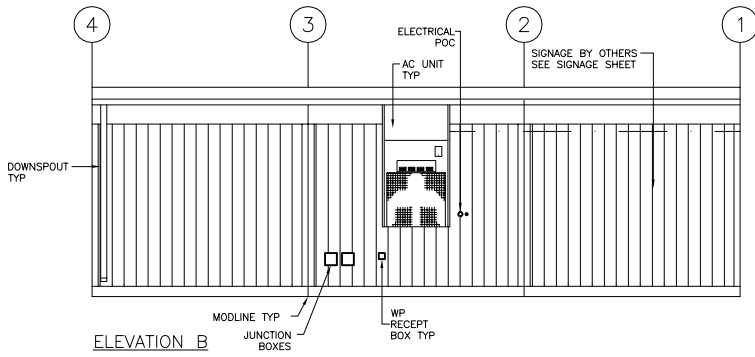

ELEVATION B

ELEVATIONS

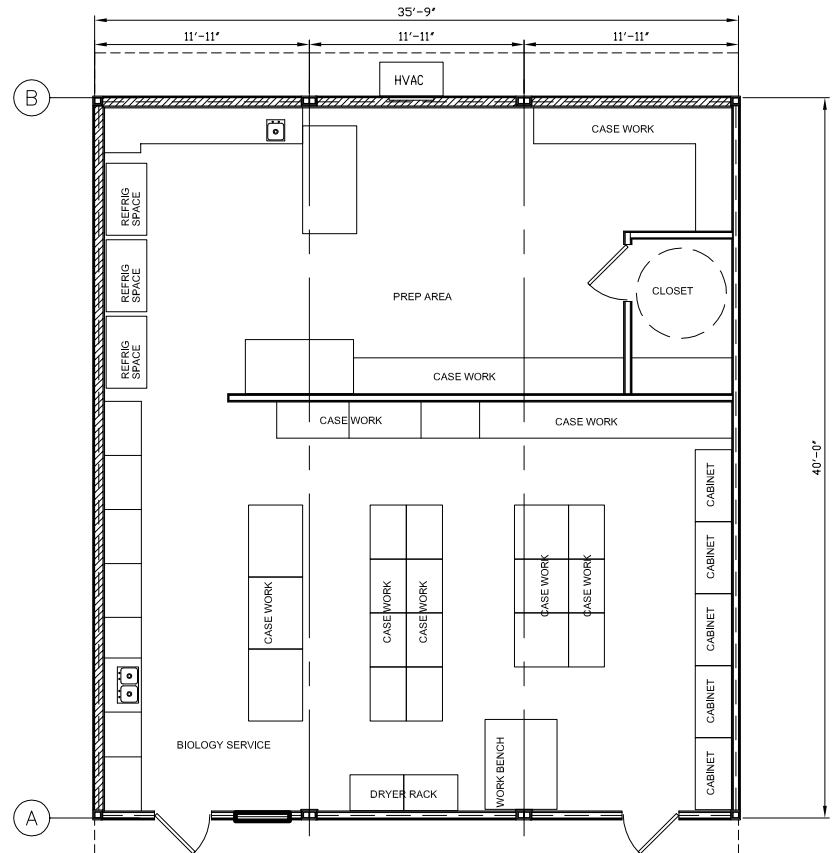

FLOOR PLAN